

USN

--	--	--	--	--	--	--	--	--	--



10ME82

**Eighth Semester B.E. Degree Examination, Jan./Feb. 2021**  
**Control Engineering**

Time: 3 hrs.

Max. Marks:100

**Note:** 1. Answer any FIVE full questions, selecting at least TWO questions from each part.  
 2. Missing data, if any, may be suitably assumed.

**PART – A**

- 1 a. Differentiate open loop control system and closed loop control system with an example. (07 Marks)  
 b. What is control action? Explain any one of its type with an example. (07 Marks)  
 c. What are the requirements of an ideal control system? Explain. (06 Marks)
- 2 a. Obtain the transfer function model of an AC motors in control system. (07 Marks)  
 b. Find the transfer function of a mechanical system shown in Fig.Q2(b) constructing free body diagram.

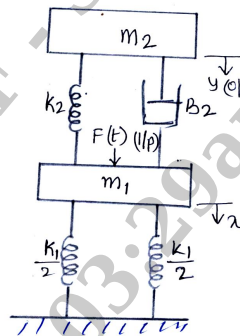

Fig. Q2(b)

(07 Marks)

- c. Obtain the mathematical modeling of a first order pneumatic system. (06 Marks)
- 3 a. Find the transfer function of a block diagram shown in the Fig.Q3(a).

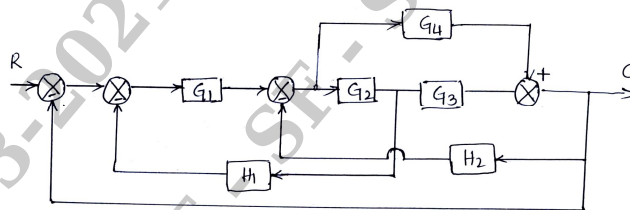

Fig. Q3(a)

(08 Marks)

- b. Using Mason's gain formula find the overall transfer function of a signal flow graph shown in Fig.Q3(b).

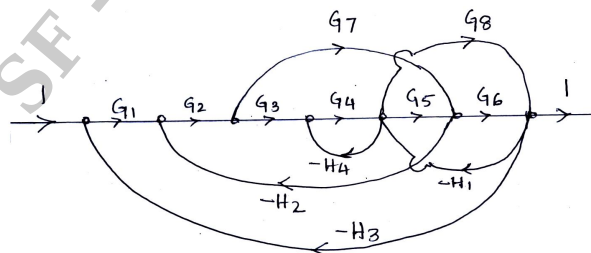

Fig. Q3(b)  
1 of 2

(12 Marks)

Important Note : 1. On completing your answers, compulsorily draw diagonal cross lines on the remaining blank pages.  
 2. Any revealing of identification, appeal to evaluator and /or equations written eg. 42+8 = 50, will be treated as malpractice.

- 4 a. Explain the different types of inputs. (05 Marks)
- b. Determine the stability of the system for the following equation using R-H criteria.  
 $s^6 + 2s^5 + 8s^4 + 12s^3 + 20s^2 + 16s + 16 = 0$ . (07 Marks)
- c. The measurement conducted on a servosystem, which shows the system response as  $C(t) = 1 + 0.25e^{-50t} - 1.25e^{-10t}$  when subjected to a unit step input. Obtain the closed loop transfer function also find  $\omega_d$  and  $\xi$ . (08 Marks)

**PART - B**

- 5 a. Draw the polar plot for  $G(s) = \frac{5(s+1)}{s(s+2)}$ . (06 Marks)
- b. Draw the Nyquist plot and analyse the stability of  $G(s) = \frac{4}{s(1+0.1s)(1+0.2s)}$ . (14 Marks)
- 6 a. What is Bode attenuation diagram? Explain. (05 Marks)
- b. Draw the Bode magnitude and phase angle plot for  $G(s) = \frac{(s+0.2)}{s(s+0.01)(s+2)(s+10)}$ .  
 Find PM, GM and K values. (15 Marks)
- 7 a. List the general rules for constructing root loci. (05 Marks)
- b. Sketch the root locus for the following OLTF  $G(s) = \frac{k(s+1)(s+2)}{(s+0.1)(s-1)}$ . (15 Marks)
- 8 a. With a neat sketch explain series and feedback system with an examples. (10 Marks)
- b. For the system shown in Fig.Q8(b), write the differential equations for the mass  $m$  and obtain the matrix representation of state equations. (10 Marks)

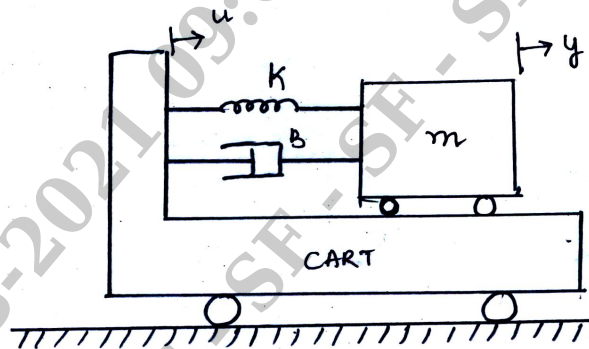

Fig.Q8(b)

(10 Marks)

\*\*\*\*\*